

## L1X/2X Series Multi-Channel Current Mode Pyroelectric Detectors

### Description

Our L1X/2X series of pyroelectric detectors are a collection of multi-channel  $\text{LiTaO}_3$  devices operating in current mode with an integrated Op-Amp.

TFC (Temperature Fluxuation Compensation) is incorporated into all of our L2X- series detectors via. the use of a optically blind element.

### Features

- Thermal based detector, any radiation absorbed produces a signal
- Wide Spectral Coverage from the UV to LWIR
- Modular design principle
- Assembled in an ISO:9001 facility
- Microphonics reduction as standard

### Applications

- Non-dispersive infrared gas analysis
- Flame and fire detection
- Non-contact temperature measurement
- Flame control
- Moisture monitoring

### Versions

- Integrated Op-Amp (Split and Single Supply)
- Low and high speed devices available
- 9 Standard window options
- 17 standard filter options (including small and large apertures)

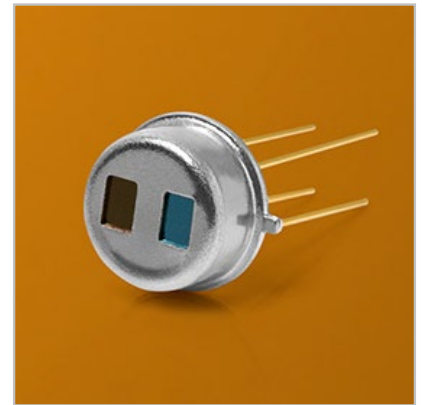

L1200X1810

- Dual Channel Pyroelectric Detector
- Current Mode
- Single Supply
- Without TFC

Isometric Drawing (with cutaway)



Circuit Diagram

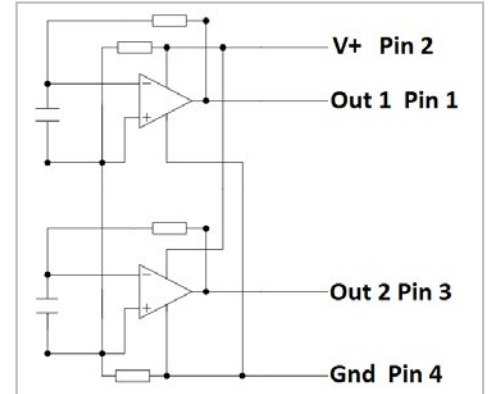

Technical Drawing

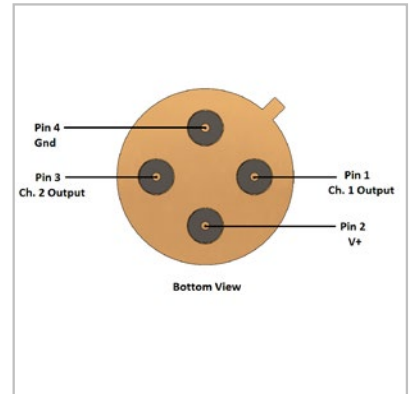
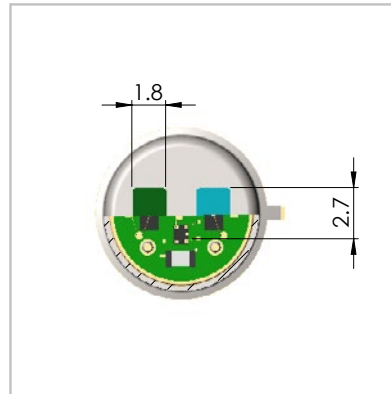
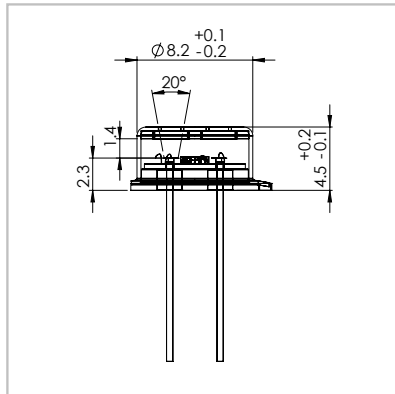

Element Size	Aperture Size	Package	Absorber	
1.8 mm x 1.0 mm	2.7 mm x 1.8 mm	TO-39 4-pin	Organic Black	
Feedback Resistor	Amplifier	-3dB Freq (Hz)	Supply Voltage [V]	
27 GOhm	Op-Amp 3	TBD	2.7-10 V (3 V recommended)	
Responsivity (V/W)	D* (Jones) @ ... Hz	Noise Density (µV/sqrt(Hz))	NEP [W/√Hz]	Polarity
Min: 25,000 Typ: 35,000	Min: 2x10 <sup>8</sup> Typ: 3x10 <sup>8</sup>	Max: 20	Max: 4x10 <sup>-10</sup>	Negative

**!** Similar Model: PY-ITV-DUAL

Please refer "Filters and Windows" datasheet for all available options

L2200X1810

- Dual Channel Pyroelectric Detector
- Current Mode
- Single Supply
- With TFC

Isometric Drawing (with cutaway)



Circuit Diagram

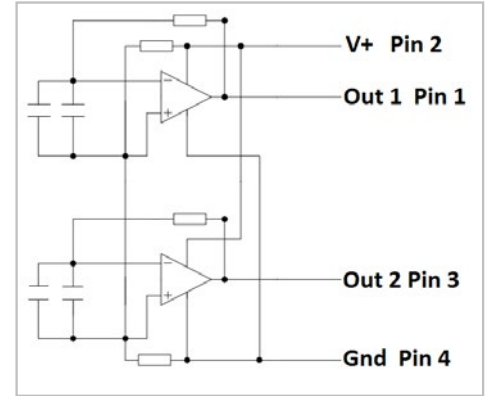

Technical Drawing

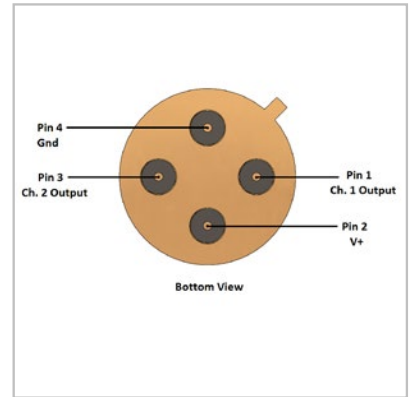
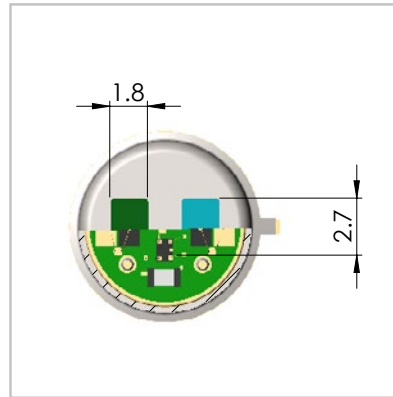
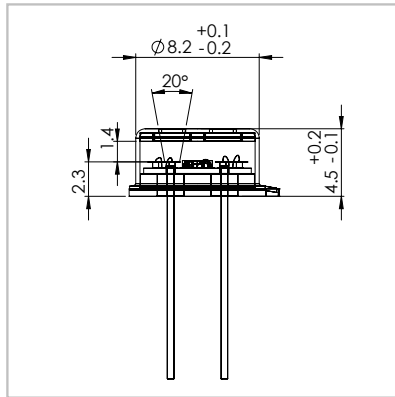

Element Size	Aperture Size	Package	Absorber	
1.8 mm x 1.0 mm	2.7 mm x 1.8 mm	TO-39 4-pin	Organic Black	
Feedback Resistor	Amplifier	-3dB Freq (Hz)	Supply Voltage [V]	
100 GOhm	Op-Amp 3	TBD	2.7-10 V (3 V recommended)	
Responsivity (V/W)	D* (Jones) @ 10 Hz	Noise Density (µV/sqrt(Hz))	NEP [W/√Hz]	Polarity
Min: 60,000 Typ: 120,000	Min: 3x10 <sup>8</sup> Typ: 5x10 <sup>8</sup>	Max: 50	Max: 3.85x10 <sup>-10</sup>	Negative

**!** Similar Model: LIE-272

Please refer "Filters and Windows" datasheet for all available options

### Absolute Maximum Ratings

	Min	Max
Storage Temperature [°C]	- 25	+ 85
Operating Temperature [°C]	- 20	+ 55
Soldering Temperature, 5 sec [°C]	+ 280	+ 300
ESD Damage Threshold, Human Body Model Class ....* [V]		TBD

\* ANSI/ESD STN5. 1-2007

### Part Number Designation

